

Syringe Pumps so Advanced...

They're **Simple!**



1

**Select
syringe**

2

**Enter
flow rate**

3

**Press
start**

The KD Scientific Advantage

KD Scientific pumps are acknowledged as the industry's highest valued solution for delivering precise and smooth flow in research, pilot plants and production applications. KD Scientific is recognized worldwide for quality, accuracy and reliability at an economical price. KD Scientific has the broadest line of syringe pumps, from a basic one syringe infuse only pump, to an advanced programmable multi-syringe infuse/withdrawal pump. KD Scientific is committed to delivering the highest level of customer satisfaction, as well as technical support for all their products.

KDS 100 Series Pumps Rich in features at an affordable price

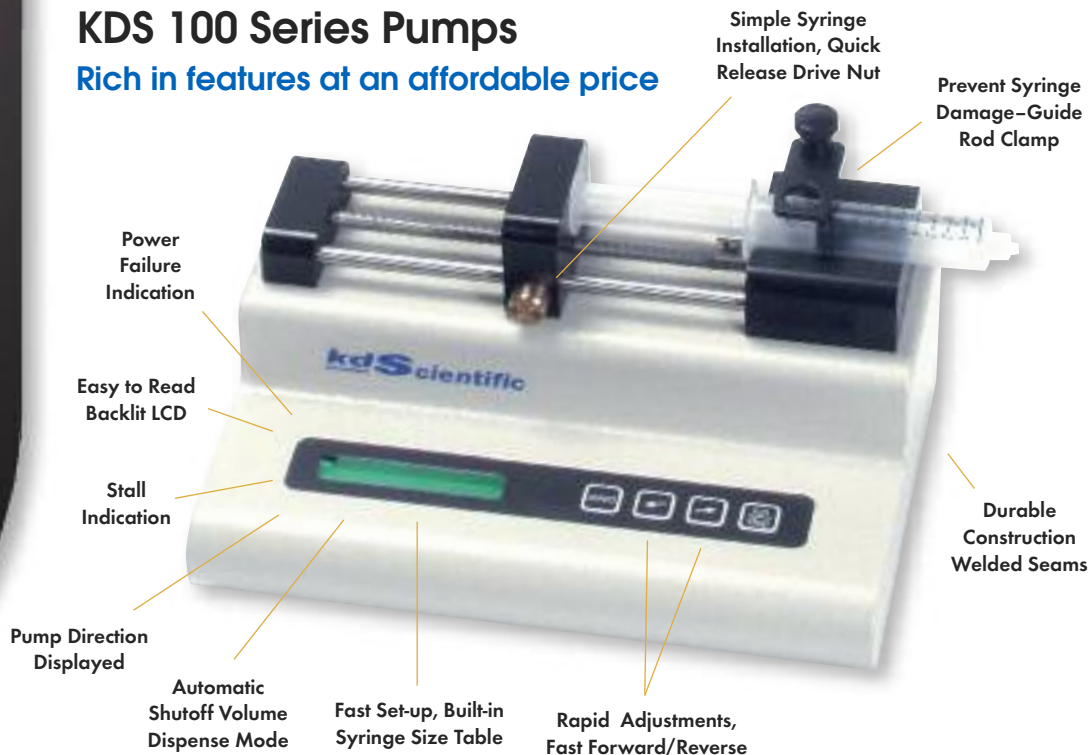

KDS 200/KDS 400 Series Pumps

All the features of a KDS 100 plus...

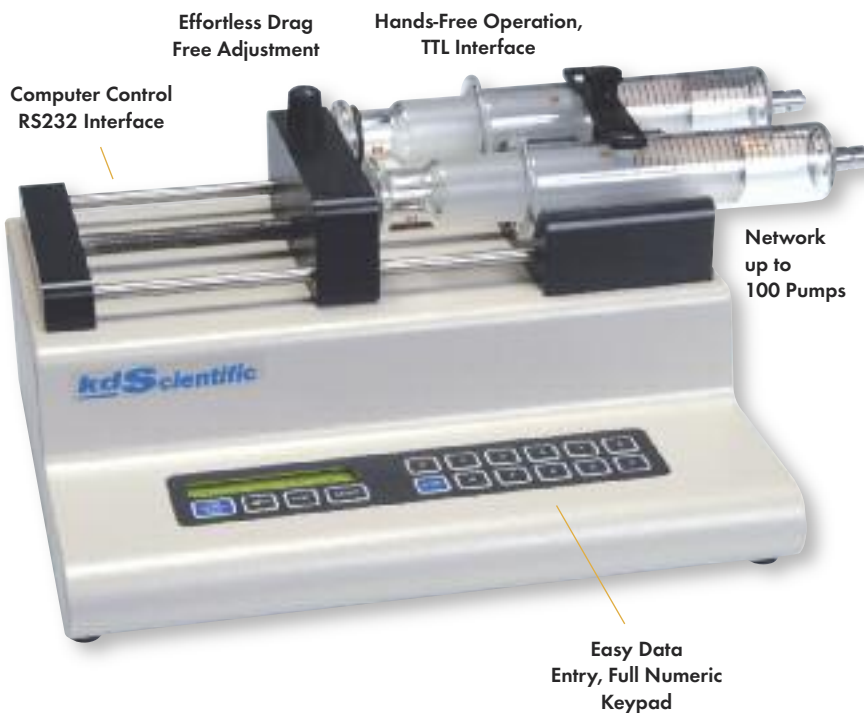

Recognized Worldwide...

KDS syringe pumps are the #1 choice of life science and industrial researchers for their:

- Easy-to-use interface for simple operation
- Rugged design for long-life and reliability
- Anti-vibration technology eliminating operational noise
- Stall detection and alarms
- Configurability for your applications:
 - Single, double, four, ten syringes
 - Infuse or infuse/withdraw or push pull
 - Programmable and advanced programmable
 - Specialized systems
 - OEM models
 - High pressure
- High performance accuracy and precision
- Broad flow rate range from high to low
- World-wide support when you need it
- RS232 and TTL I/O
- No fan, eliminates thermal and environmental contamination for higher reliability and operation

kdScientific

Application Areas *peer endorsed!*

The following is an extensive list of application areas in which syringe pumps are utilized. The superior performance of KDS syringe pumps has made them prominent in publications for their outstanding performance, smooth flow and rugged design. Bibliographies and publications are available at:

www.kdscientific.com



Uses of Syringe Pumps

- Calibration
 - Diluting
 - Dispensing
 - Dosing
 - Emulsification
 - Fluid Transfer
 - Infusion of Fluids
 - Mixing
 - Perfusion
 - Timed Delivery
 - Withdrawal of Fluids
 - Slow Infusion
 - Volumetric Dispensing
- MS Calibration
 - Microfluidics/Microfluidic Channel Injections
 - Surface Plasma Resonance
 - Biotech Research and Development
 - Drug Discovery
 - Neuroscience
- Organic Synthesis
 - Aerosol Injection/ Nebulization
 - Agriculture
 - Animal Drug/Nutrient Injections
 - Automotive Research
 - Cell Injections
 - Chemical Development
 - Pilot Plant Reactor Dosing
 - Continuous Flow
 - Dye Dilution
 - Dye/Isotope Injection
 - Electro-Spinning
 - Emulsification
 - Emulsion Polymerization
 - Entomology
 - Geological Sampling
 - Isotope Injections
 - Liquid Chromatography Injections
 - Metered Dispensing
 - Microdialysis
 - Micro-Filtration
 - Perfusion
- Pharmaceutical Development
 - Polymer Research
 - Post Column Addition
 - Electrospray (ESI-MS)
 - HPLC Mass Spec
 - Lock Mass Infusion/Calibration
 - MALDI-TOF Matrix Addition
 - Nano Flow Rates
 - Precision Mass Spec
 - Capillary Electrophoresis
 - Cell Manipulation
 - Cell Patterning
 - Cell Separation
 - Chemical Binding Coefficients
 - Chemical Gradient Formation
 - Enzyme Reaction Kinetics
 - Flow Cytometry
 - Fluid Viscosity
 - Immunoassays
 - Reactor Injections
 - Toxicology Studies
 - Viscosity/Viscometer Systems
 - Weather Research

Infusion Pumps *performance, reliability & value!*

KD scientific infusion pumps are ideal for delivering accurate and precise amounts of fluids for a multitude of applications, including injection of calibrant into a mass spectrometer or reaction chamber, long term drug delivery to animals and general infusion applications. Customers use the KDS 100/KDS 200 syringe pumps more than any other for their outstanding reliability and performance. The KDS 100 series pumps give customers the most cost effective solution for infusing fluids. Alternatively, the KDS 200/KDS 400 series gives the customer advanced features with RS232 and TTL interfaces. All KDS 200/KDS 400 series pumps can be daisy chained together to create a pumping network.



KDS 100 Single-Syringe Infusion Pump

This economical Single Syringe Infusion Pump combines precision flow with outstanding ease-of-use and exceptional durability.

- Single syringe 10 μ l to 60 ml
- Wide flow range up to 519 ml/hr



KDS 200 Two-Syringe Infusion Pump

This feature-laden Two-Syringe Infusion Pump combines a broad speed range and holds a wide range of syringe sizes to meet the requirements of virtually any laboratory application.

- Minimum flow 0.001 μ l/hr with 10 μ l syringe
- Holds one or two syringes, 10 μ l to 140 ml each



KDS 101 Two-Syringe Nanoliter Pump

The KDS 101 Two-Syringe Nanoliter Pump is ideal for microdialysis and similar applications which require virtually pulseless flow at very low flow rates.

- Holds 2 syringes, 10 μ l to 10 ml each or, a single syringe up to 60 ml
- Minimum flow 0.001 μ l/hr (10 ml syringe)



KDS 220 Multi-Syringe Infusion Pump

KDS 220 Multi-Syringe Infusion Pump is ideal for applications requiring multiple syringes. This pump has been modified to hold up to 10 syringes.

- Multiple syringe holder:
 - One to ten syringes, 10 μ l to 10 ml
 - One to six syringes, 20 ml to 60 ml
 - One to four syringes, 100 ml to 140 ml



KDS 250 Four-Syringe Nanoliter Infusion Pump

Each syringe can be sized differently and is clamped independently.

- Multiple syringe holder
 - Four syringes, 10 μ l to 10 ml each
- Separate clamping accommodates various sizes
- Syringes may be positioned independently for sequential dispensing by the pusher block.

Infusion/Withdrawal Pumps *most versatile*

Infuse and withdraw capabilities provide maximum flexibility for varied applications. This feature permits applications, such as automatic withdrawal of samples and unattended filling of syringes at very low flow rates. The unique KDS 310 offers a remote pump head, which is perfect when space is limited. The small size and exceptional low flow rate capability allows direct mounting of the KDS 310 on a stereotaxic manipulator without the need for long narrow tubing which is both difficult to use and requires larger volumes of valuable fluids.



KDS 210 **Two-Syringe** **Infusion/Withdrawal Pump**

The KDS 210 offers you more advanced features than any other infusion/withdrawal pump in its price range- including five operating modes plus independent rate and volume settings for both infusion and withdrawal.

- Holds two syringes, 10 μ l to 140 ml each
- Multiple mode selection:
 - Infusion, Withdrawal, Infusion then Withdrawal, Withdrawal then Infusion, Continuous Cycle

KDS 230 **Multi-Syringe** **Infusion/Withdrawal Pump**

Ideal for applications requiring multiple syringes, the KDS 230 is an adaptation of the KDS 210. The pump has been modified to hold up to 10 syringes.

- Multiple syringe holder:
 - One to ten syringes, 10 μ l to 10 ml
 - One to six syringes, 20 ml to 60 ml
 - One to four syringes, 100 ml to 140 ml
- Multiple mode selection:
 - Infusion, Withdrawal, Infusion then withdrawal, Withdrawal then Infusion, Continuous Cycle



KDS 310 Plus **Nanoliter Syringe Pump**

The KDS 310 Nano Pump is used exclusively with micro syringes. Small size, remote pump head and a rugged mounting arm make it ideal for use with micromanipulator, stereotaxic and other clamping devices.

- Mini size pump
- Remote pump head
- 1 μ l to 250 μ l syringe
- Minimum flow of 0.001 μ l/min

Push-Pull Pumps *superior simultaneous infuse/withdraw*

These proven KDS pumps provide simultaneous infusion and withdrawal with opposing syringes on a single drive. The KDS 120 and KDS 260 are adaptations of the KDS 100 and KDS 210, respectively. Each has been modified to hold an additional syringe so that as one syringe infuses, the second syringe withdraws at the same rate.



KDS 260 Four-Syringe Push-Pull Pump

This KDS 260 pump provides simultaneous infusion and withdrawal with opposing syringes on a single drive.

Note: When not used in push/pull mode, the pump has all the features of KDS 210

- Holds up to four syringes, 10 μ l to 60 ml each. With large syringes, the full volume

Alarm Option

The alarm option can be added to any KDS pump. An audible alarm will sound when the pump is done dispensing.



KDS 120 Two-Syringe Nanoliter Push-Pull Pump

This pump provides simultaneous infusion and withdrawal at the same rate with opposing syringes on the same drive screw. The Push/Pull mode is designed for one cycle only.

- Holds two syringes 10 μ l to 10 ml each
- Minimum flow 0.1 μ l/hr (10 μ l syringe)

Specialty Pumps *customized for maximum performance*

KD Scientific specialty pumps are engineered to meet the demands of specific applications. These pumps use the basic design of our standard pumps but are modified to provide specific functionality for any application.

The KDS 330 Emulsifier Pump is an adaptation of the KDS 210 with a customized syringe mechanism which allows the pump to move the fluid back and forth continually through an emulsion needle.

The KDS 410 is a high pressure pump based on the KDS 210 with a different motor and rugged syringe mechanism to hold the syringe.

The KDS 270 was designed for long term fluid delivery. With valves and tubing the unit can continuously run by drawing fluid from a reservoir.



KDS 270 Continuous Cycle Syringe Pump

The KDS 270 can hold up to four syringes and can cycle continuously back and forth in a push-pull action. As two syringes are infusing, two syringes are withdrawing at the same rate. At the end of the set volume the direction is automatically reversed and the next cycle begins. With the use of 3-way valves, the pump can empty and refill syringes for a continuous dispense.

- Holds four syringes, 10 μ l to 60 ml each. With large syringes the full volume may not be useable. [60 ml syr - 40 ml useable, 30 ml syr - full]

KDS 330 Emulsifier Pump

The model KDS 330 is designed to emulsify viscous fluids/suspensions by moving them back and forth through an emulsifying needle. The pump reduces fatigue and time required to manually prepare

The KDS 330 is ideal to prepare an adjuvant/antigen mixture to the correct viscosity, ready for injection. The pump is based on the KDS 210 in continuous mode for cycling back and forth and is specifically designed for a 10 cc glass syringe and emulsion needle.



- Simple control using a keypad, menu selection and a LCD display
- Volume setting and automatic cycling
- Rate setting
- Settings stored in memory
- Stall detection

KDS 410 High Pressure Syringe Pump

The KDS 410 is ideal for delivering fluid to reactors in chemical applications or for working with viscous fluids. The robust design ensures the syringe is kept level during delivery of the fluid. The KDS 410 more than doubles the linear force available in the KDS 200 series.

- Single syringe 10 μ l to 140 ml
- Minimum flow 0.001 μ l/hr with a 10 μ l syringe
- > 100 lbs linear force

Ideal for use
with KDS Stainless
Steel Syringes!
see page 10.



NEW Customizable OEM Modules

Pump customization is now easier with the new KDS OEM modules. Integrate these modules into your systems or work with our KDS engineering staff to design different syringe mechanisms or controllers. KDS offers the technology and engineering expertise to meet your demanding applications.

The microliter and milliliter modules incorporate lead free design, ensuring full compliance with the Waste Electrical and Electronic Equipment (WEEE) and Restriction on the use of Hazardous Substances (RoHS) standards.

The NEW KDS 900 Microliter and KDS 910 Milliliter syringe pump modules are highly precise...

This is the ideal pump for OEM applications. It has two modes of operation—constant flow rate or volume dispense. Infuse and withdraw limit switches indicate when the syringe has reached the end of travel (infuse switch) or the syringe plunger has been withdrawn to its limit (withdraw switch). If either switch is activated, the pusher block movement is stopped.

Syringe diameter, flow rates, and target volumes are stored in non-volatile memory. Interface to the pump modules is through RS232.

- Constant Current Drive offers more consistent force delivery over the entire dynamic flow rate range.
- Independent infuse and withdraw limit switches
- Linear Force – minimum of 25 lbs over entire range (KDS 910)
Minimum 7 lbs over entire range (KDS 900)
- Emergency stop switch at pump
- Start/stop at pump
- Encoder for stall detection
- Power and run LED on the PC Board
- Supports external run LED
- Network up to 16 pumps
- $\pm 0.5\%$ Accuracy (KDS 910)
- $\pm 0.35\%$ Accuracy (KDS 900)
- Pump setting retained in NVRAM
- Adjustable force control
- Easily mounts to panel openings
- Customizable syringe mechanisms available
- Customizable chassis designs available
- Lead Free Design, RoHS compliant
- CE approved



NEW KDS 900 Customizable μ l OEM Module

- 0.5 μ l to 1 ml syringe
- Minimum flow rate 0.001 μ l/hr (0.5 μ l syringe)
- $\pm 0.35\%$ Accuracy
- Maximum flow rate 1.330 ml/min (1 ml syringe)

NEW KDS 910 Customizable milliliter OEM Module

- 0.5 μ l to 50/60 ml syringes
- Minimum flow rate 0.001 μ l/hr (0.5 μ l syringe)
- $\pm 0.5\%$ Accuracy
- Maximum flow rate 44.28 ml/min (50/60 ml syringe)



maximum performance with minimal development

Commands

Powerful programming features for advanced pump control:

- Start or stop pump
- Change pump direction—Infuse/Withdraw
- Clear volume accumulator
- Change flow rates
- Set target dispense volume
- Set syringe size
- Set force value

Queries

Syringe diameter • Rate • Volume • Accumulated volume

KDS 900 Shown
(KDS 910 features are similar)

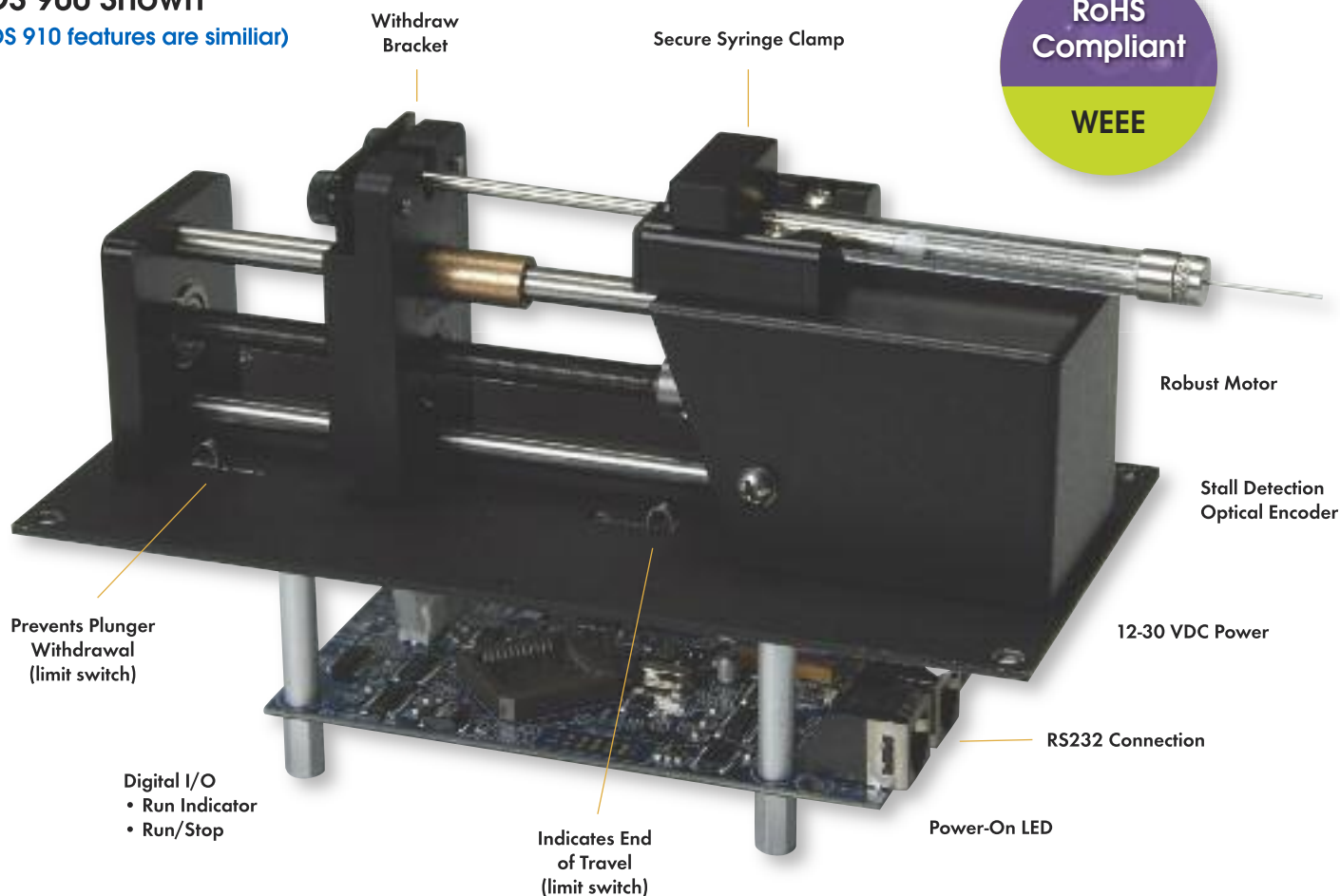

NEW Pump Systems *for enhanced performance*

The KDS 100 series has been modified with new hardware and software features for specific applications. Integrating multiple pumps in a system allows the individual pumps to interact with other ones. This will provide a system linked together based on information from one pump being transferred to another.

In addition, new features have been added to the KDS 100 Series including a new remote interface or an LED on the pump to indicate it is running. Contact KD Scientific for more information on other requirements you have for your specific applications.



NEW KDS 520 Volume Dispense System

Sequential volume dispensing is easy with the new volume dispensing system. The system includes two KDS 100 pumps and the cable to link the pumps together. Set the same or different volume[s] in pump A and B; pump A will dispense the predetermined volume and start pump B automatically. Pump A and B can have unique flow rates. The two pumps can also be operated as standard independent KDS 100's.



NEW KDS 510 Dual Rate Pump System

Activate two KDS 100 pumps simultaneously with one push of the start key. Set each pump with a different flow rate and the pumps will infuse at the same time. The system includes two KDS 100 pumps and the cable to link the pumps together. The two pumps can also be operated as standard independent KDS 100's.



NEW KDS 100Y with Remote Operation

A new version of the rugged KDS 100 can now be remotely triggered with a footswitch or external switch. Starting and stopping dispense or infusion can be automated or remotely activated.

Also Available: 101Y, 120Y, 310Y



NEW KDS 100L with LED Indication

The KDS 100 is now available with an optional LED to indicate the pump is on or running. This feature is ideal to get a quick indication if the pump is dispensing, especially if multiple pumps are in operation.

Also Available: 101L, 120L, 310L

Expanded Capabilities *easy to program*

Network Multiple Pumps

Network up to 100 Pumps—Mix and Match any KDS 200/400 Series Pump!

All KDS 200/400 series pumps can be networked together. Each pump has a unique address to control its rate and volume remotely from a computer. Pump start/stop activation can be easily controlled. National Instruments certified Labview™ drivers are available at no charge.

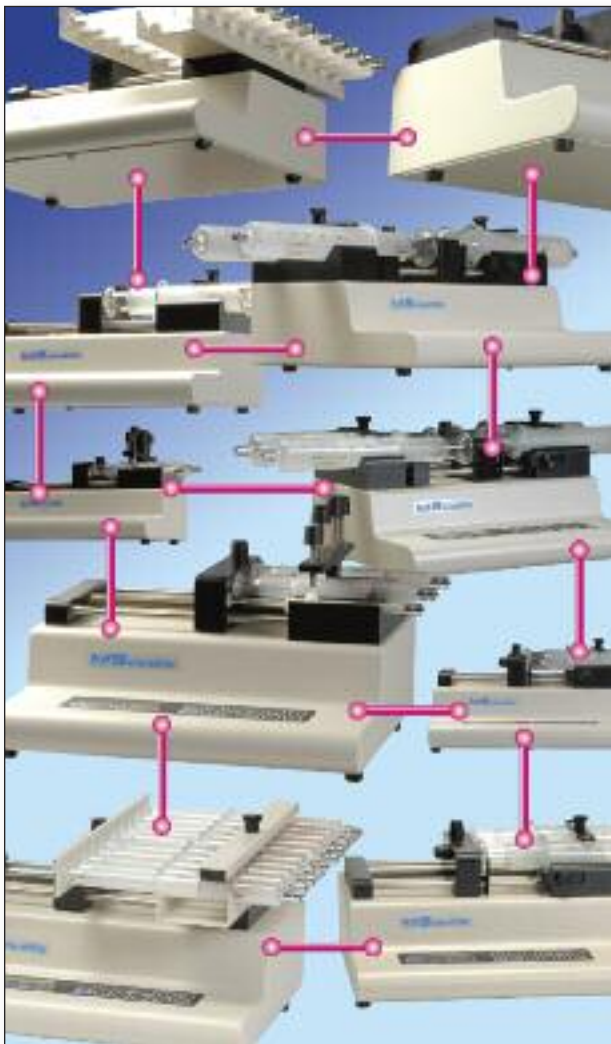
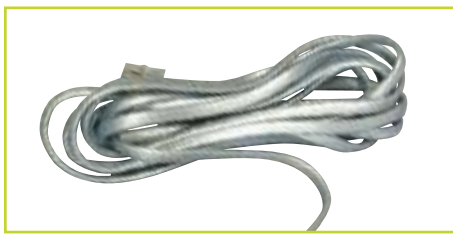

Advanced Programmable Pumps

Keypad programmable option now available with all KDS 200/KDS 400 Series syringe pumps. Lets you program right from the keypad with software program on computer.

Simply follow a few menu-driven prompts and in just minutes you can customize a program to: control the pump from seconds to days, change flow rates, pause, ramp rates up or down automatically, control outputs and respond to external TTL signals.

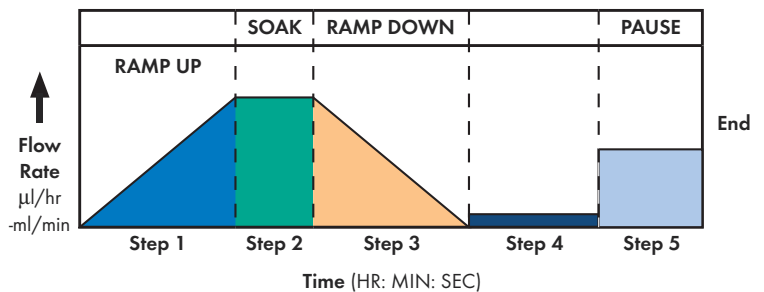

Unlike other programmable pumps, there's no need to enter time increments or decrements between start and end flow rates. KDS pumps provide a smooth, linear transition automatically.

A program is divided into eight variable time periods called steps. A step can be up to 12 hours long and may be changed without affecting other steps.



Each step offers these options:

1. Time duration, from one second up to 12 hours
2. Travel direction – Infuse or withdraw (where available)
3. Beginning flow rate ($\mu\text{l/hr}$ to ml/min range)
4. End flow rate ($\mu\text{l/hr}$ to ml/min range)
5. Pause – Waits for an external trigger to start
6. Status of output TTL pins
7. Loop option – Loops back to any previous step and repeats the intermediate steps. Two separate loops available.
8. Set the count in the loop cycle. Steps may be repeated up to 100 times.
9. Program stored in non volatile memory.

Stainless Steel Syringes



Stainless Steel Syringes

Premium Line of Stainless Steel Syringes

A premier line of stainless steel syringes is now offered by KD Scientific. These syringes are a perfect compliment for the NEW KDS 410 high force pump. Rugged stainless steel syringes are an ideal solution when the pressures and the force are high, completely eliminating the problem of breaking glass syringes.

Stainless steel offers good resistance to most aggressive liquids. Wetted parts are #316 stainless steel and Viton or Perfluoroelastomer. Syringes are available in 2.5, 8, 20, 50 and 100 sizes with removable, replaceable tips. Genuine SWAGelok™ syringe to tube fittings are available in 1/16, 1/8 and 1/4 inch sizes. A luer lock end fitting is also available. Tips are interchangeable with all syringes from 20 to 100 ml in size.

- Compatible with most syringe pumps
- Eliminate hazards of glass syringe breakage
- Adaptable to Luer Lock or Swagelok™ fittings
- Rugged construction #316 stainless steel
- Reuseable - fully autoclavable
- Resistance to most chemicals

Specifications

Volume	2.5 ml		8 ml		20 ml		50 ml		100 ml	
Dimensions:	in	(mm)	in	(mm)	in	(mm)	in	(mm)	in	(mm)
Overall Length of Barrel - (L1)	6.64	(168.7)	6.73	(170.8)	4.73	(120.0)	5.49	(139.3)	6.73	(170.9)
Stroke - (S)	5.41	(137.4)	4.42	(112.4)	2.74	(69.6)	3.06	(77.83)	4.12	(104.5)
Outside Diameter - (OD)	0.50	(12.7)	0.50	(12.7)	0.88	(22.2)	1.25	(31.8)	1.50	(38.1)
Inside Diameter - (ID)	0.191	(4.85)	0.375	(9.525)	0.753	(19.13)	1.126	(28.60)	1.374	(34.90)
Maximum Test Pressure	9000 psi		4000 psi		1500 psi		1500 psi		1500 psi	
Working Pressure	7000 psi		1500 psi		700 psi		700 psi		700 psi	
Order Code Syringe with Swagelok™ 1/16"	780801		780802		780803		780804		780805	
Order Code Syringe with Swagelok™ 1/8"	N/A		780807		780808		780809		780810	
Order Code Syringe with Swagelok™ 1/4"	N/A		N/A		780812		780813		780814	
Order Code Syringe with Luer Lock	N/A		N/A		780816		780817		780818	
O-Ring Material Standard	Balseal		Perfluoroelastomer		Viton		Viton		Viton	
O-Ring Specials	N/A		N/A		Perfluoroelastomer		Perfluoroelastomer		Perfluoroelastomer	

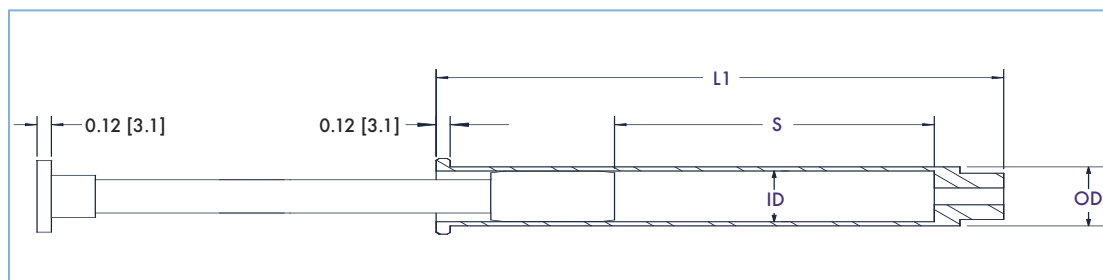

Syringe	Fitting	L3 in (mm)
2.5 to 8 ml	1/16	0.74 (18.8)
2.5 to 8 ml	1/8	0.91 (23.1)
20 to 100 ml	1/16	0.67 (17.0)
20 to 100 ml	1/8	0.84 (21.3)
20 to 100 ml	1/4	0.94 (23.9)
20 to 100 ml	Luer	1.34 (34.0)

Glass Syringes & Accessories



Glass Syringes

KD Scientific Line of Glass Syringes

KD Scientific offers a new line of glass syringes to meet scientific applications in the laboratory environment. Over ten different sizes of glass syringes ranging from 1.0 ml to 150 ml are available.

All syringes are made from heat resistant borosilicate glass. The material and construction are resistant to breakage from shock and sudden temperature changes. They are all annealed and tested until free of internal strain to withstand repeated washing.

- Easy to clean and maintain
- Accurate dispensing
- Reusable
- Economical
- Durable
- Chemically resistant
- Resistant to thermal shock

Specifications

Order Code	780871	780872	780873	780874	780875	780876	780877	780878	780879
Volume	1.0 ml	2.0 ml	5.0 ml	10.0 ml	20.0 ml	30.0 ml	50.0 ml	100.0 ml	150.0 ml

Accessories

KDS 100 shown

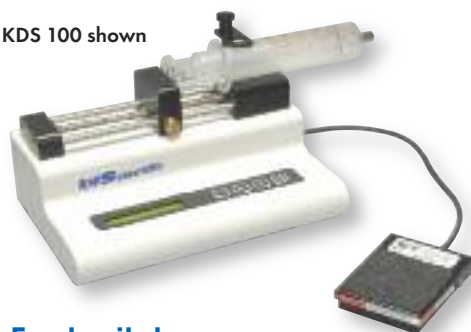

Footswitch

Remotely start/stop the KDS 200/KDS 400 series pumps with the KDS footswitch. Plugs directly to the TTL interface on the KDS 200/KDS 400 series of pumps. The KDS 100Y series and KDS 310Y also work with a footswitch.

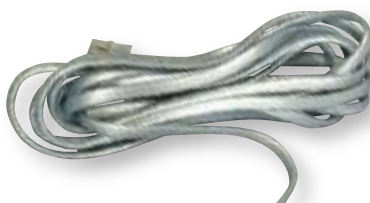

Daisy Chain Cable

Connect multiple pumps together. Daisy chain up to 100 KDS 200/KDS 400 series pumps through the daisy chain cable. Simply connect the first pump to the second pump with one cable and use additional cables to chain the pumps together. Each pump can be given a remote address in software. Communication to each pump can be done through the RS232 interface.



RS232 Cable

9 pin female connector with RJ 11 interface to KDS 200/KDS 400 series pumps.

NIST Traceable Option Certificate

KD Scientific offers a National Institute of Standard and Testing (NIST) certificate on all models of KDS Pumps. It is a certificate validating the flow rates indicating the performance results of the pumps against our certified standards.

Pump Specifications

The KDS Advantage

General Features Available on ALL pumps:

- Vibration Elimination System
- Flow Direction Indicator
- Fast Forward/Reverse
- Antisiphon Clamp (I/W Models only)
- CE Approved Model 100 series are ETL listed and conforms to ANSI/UL Standard 61010-1:2004 2ND ED. Certified to CAN/CSA STD C22.2NO.61010.1:2004 2ND ED
- Power Recovery Diagnostics
- Optional Foot Pedal Interface
- NIST Certificate Option
- Alarm Option
- CE Approved Models

Basic Programming

- Syringe Library
- Flow Rate Selection
- Volume Dispense Mode
- Direct Entry Syringe Diameter

Standard on KDS 200/KDS 400 Pumps

- Daisy Chain Connection
- RS232
- TTL
- Foot Switch Interface Standard
- Stall Detection
- Numeric Keypad
- Engineering Unit Selection

Infusion Pumps

Model	KDS 100	KDS 100 L	KDS 100 Y	KDS 101
Syringes Max. No. and Size	One 10 µl - 60 ml ea.	One 10 µl - 60 ml ea.	One 10 µl - 60 ml ea.	Two 10 µl - 10 ml ea.
Dimensions	9 x 6 x 5 in (23 x 15 x 12 cm)	9 x 6 x 5 in (23 x 15 x 12 cm)	9 x 6 x 5 in (23 x 15 x 12 cm)	9 x 6 x 5 in (23 x 15 x 12 cm)
Weight	4.5 lb (2 kg)	4.5 lb (2 kg)	4.5 lb (2 kg)	5 lb (2.3 kg)
Min. Flow Rate (10 µl syr)	0.1 µl/hr	0.1 µl/hr	0.1 µl/hr	0.001 µl/hr
Max. Flow Rate				
10 ml syringe	127 ml/hr	127 ml/hr	127 ml/hr	0.351 ml/min
60 ml syringe	519 ml/hr	519 ml/hr	519 ml/hr	-
140 ml syringe	-	-	-	-
Linear Force	20 lb (9 kg)	20 lb (9 kg)	20 lb (9 kg)	40 lb (18 kg)
Advance per Microstep	0.529 micron (1/2 step)	0.529 micron (1/2 step)	0.529 micron (1/2 step)	0.088 micron (1/2 step)
Max. Step Rate	400/sec (1/2 step)	400/sec (1/2 step)	400/sec (1/2 step)	400/sec (1/2 step)
Min. Step Rate	1/30sec (1/2 step)	1/30sec (1/2 step)	1/30sec (1/2 step)	1/30sec (1/2 step)
Accuracy	± < 1%	± < 1%	± < 1%	± < 1%
Reproducibility	± 0.1%	± 0.1%	± 0.1%	± 0.1%
Programmable Model	-	-	-	-

Model	KDS 200	KDS 220	KDS 250
Syringes Maximum No. and Size	Two 10 µl - 140 ml ea.	Ten 10 µl - 10 ml ea. Six 20 ml - 60 ml ea. Four 100 ml - 140 ml ea.	Four 10 µl - 10 ml ea. (each syringe can be a different size)
Dimensions	11 x 9 x 6 in (28 x 23 x 15 cm)	11 x 12 x 6 in (28 x 30 x 15 cm)	11 x 9 x 6 in (28 x 23 x 15 cm)
Weight	9 lb (4 kg)	9.5 lb (4.3 kg)	9 lb (4 kg)
Min. Flow Rate (10 µl syr)	0.001 µl/hr	0.001 µl/h	0.001 µl/hr
Max. Flow Rate			
10 ml syringe	21 ml/min	21 ml/min	21 ml/min
60 ml syringe	86 ml/min	86 ml/min	-
140 ml syringe	145 ml/min	145 ml/min	-
Linear Force	40 lb (18 kg)	40 lb (18 kg)	40 lb (18 kg)
Advance per Microstep	0.165 micron (1/16 step)	0.165 micron (1/16 step)	0.165 micron (1/16 step)
Max. Step Rate	1600/sec (1/2 step)	1600/sec (1/2 step)	1600/sec (1/2 step)
Min. Step Rate	1/100sec (1/16 step)	1/100sec (1/16 step)	1/100sec (1/16 step)
Accuracy	± < 1%	± < 1%	± < 1%
Reproducibility	± 0.1%	± 0.1%	± 0.1%
Programmable Model	KDS 200P	KDS 220P	KDS 250P

Audible alarm option available with all pumps. Advanced programmable option available with all 200/400 Series pumps.

NOTE: KD SCIENTIFIC SYRINGE PUMPS ARE FOR LABORATORY USE ONLY. THEY HAVE NOT BEEN APPROVED BY THE FDA FOR CLINICAL USE ON HUMANS.

All models available 115/230 VAC 50/60 Hz and with CE mark. All specifications subject to change at any time.

* Pump head dimensions. ** Using 1 µl syringe.

Infusion/Withdrawal Pumps

Model	KDS 210	KDS 230	KDS 310 Plus	KDS 410	KDS 270
Syringes Max. No. and Size	Two 10 µl - 140 ml ea.	Ten 10 µl - 10 ml ea. Six 20 ml - 60 ml ea. Four 100 ml - 140 ml ea.	One 1 µl - 250 µl	One 10 µl - 140 ml	Up to Four 10 µl - 60 ml
Dimensions	11 x 9 x 6 in (28 x 23 x 15 cm)	11 x 12 x 6 in (28 x 30 x 15 cm)	7 x 1.7 x 2 in (17.8 x 4.4 x 5.1 cm)*	6 x 11 x 9.5 in (15 x 28 x 24 cm)	11 x 9 x 6 in (28 x 23 x 15 cm)
Weight	9 lb (4 kg)	9.5 lb (4.3 kg)	4 lb (2 kg)	14.1 lb (6.4 kg)	9.5 lb (4.3 kg)
Min. Flow Rate (10 µl syr)	0.001 µl/hr	0.001 µl/hr	0.001 µl/min**	0.001 µl/hr	0.001 µl/hr
Max. Flow Rate 10 ml syringe 60 ml syringe 140 ml syringe	21 ml/min 86 ml/min 145 ml/min	21 ml/min 86 ml/min 145 ml/min	145.6 µl/min (100 µl syringe) –	1270 ml/hr 4234 ml/hr 8824 ml/hr	21 ml/min 70 ml/min –
Linear Force	40 lb (18 kg)	40 lb (18 kg)	2 lb (0.9 kg)	>100 lb (45 kg)	40 lb (18kg)
Advance per Microstep	0.165 micron (1/16 step)	0.165 micron (1/16 step)	1.58 micron (1/2 step)	0.165 micron (1/16 step)	0.165 micron (1/16 step)
Max. Step Rate	1600/sec (1/2 step)	1600/sec (1/2 step)	916/sec (1/2 step)	1600/sec (1/2 step)	1600/sec (1/2 step)
Min. Step Rate	1/100sec (1/16 step)	1/100sec (1/16 step)	1/4 sec (1/2 step)	1/120sec (1/16 step)	1/100sec (1/16 step)
Accuracy	± < 1%	± < 1%	± < 1%	± < 1%	± < 1%
Reproducibility	± 0.1%	± 0.1%	± 0.1%	± 0.1%	± 0.1%
Advanced Programmable Model	KDS 210P	KDS 230P	–	KDS 410P	KDS 270P

OEM Pumps

Model	KDS 900 Microliter	KDS 910 Milliliter	Push-Pull Pump Systems	
			KDS 120	KDS 260
Syringes Max. No. and Size	One 0.5 µl - 1 ml	One 0.5 µl - 60 ml	One + One 10 µl - 10 ml ea.	Two + Two 10 µl - 60 ml ea.
Dimensions	7.25 x 3.63 x 4.5 in (18.41 x 9.2 x 11.43 cm)	9.5 x 4.25 x 5.3 in (24.1 x 10.8 x 12.135 cm)	9 x 6 x 6 in (23 x 15 x 14 cm)	11 x 9 x 6 in (28 x 23 x 15 cm)
Weight	1.8 lb (0.8 kg)	2.72 lb (1.23 kg)	5 lb (2.3 kg)	9.5 lb (4.3 kg)
Min. Flow Rate (10 µl syr)	0.013 µl/hr	0.013 µl/hr	0.1 µl/hr	0.001 µl/hr
Max. Flow Rate 10 ml syringe 60 ml syringe 140 ml syringe	1.408 µl/min** – –	13.286 ml/min 44.28 ml/min –	127 ml/hr – –	21 ml/min 86 ml/min –
Linear Force	7 lb (peak) Adj.	25 lb (peak) Adj.	20 lb (9 kg)	40 lb (18kg)
Advance per Microstep	0.0827 micron (1/16 step)	0.0827 micron (1/16 step)	0.529 micron (1/2 step)	0.165 micron (1/16 step)
Max. Step Rate	4000/sec (1/4 step)	4000/sec (1/4 step)	400/sec (1/2 step)	1600/sec (1/2 step)
Min. Step Rate	1/3.8 sec (1/16 step)	1/3.8 sec (1/16 step)	1/30sec (1/2 step)	1/100sec (1/16 step)
Accuracy	± < 0.35%	± < 0.5%	± < 1%	± < 1%
Reproducibility	± 0.1%	± 0.1%	± 0.1%	± 0.1%
Advanced Programmable Model	–	–	–	KDS 260P

kdScientific

Syringe Pumps So Advanced, They're Simple



84 October Hill Road, Holliston, MA 01746
phone **508.429.6809** fax **508.893.0160**
e-mail info@kdscientific.com

www.kdscientific.com